

# Spreading Wings S1000+

User Manual V1.4

2016.01

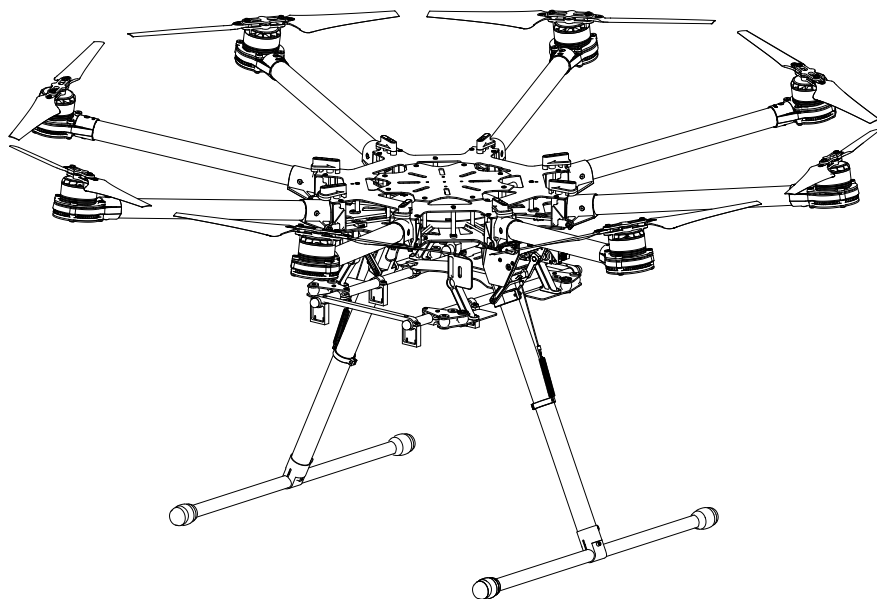

# Disclaimer

Thank you for purchasing the S1000+. Please visit the Spreading Wings S1000+ page on [www.dji.com](http://www.dji.com) regularly to keep up to date with product information, technical updates and manual corrections. Information in this manual is subject to change without notice.

In using this product, you hereby agree to this disclaimer and signify that you have understood all points completely. When assembling this product, follow all instructions carefully. The manufacturer and seller assume no liability for any damage or injury arising from the use of this product.

This is a class A product of the FCC certification. In a domestic environment this product may cause radio interference, in which case the user may be required to take adequate measures.

DJI is a registered trademark of DJI. Names of product, brand, etc., appearing in this manual are trademarks or registered trademarks of their respective owner companies. This product and manual are copyrighted by DJI with all rights reserved. No part of this product or manual shall be reproduced in any form without the prior written consent or authorization of DJI.

# About

The S1000+ is designed for professional aerial photography and cinematography. It is user friendly, safe, stabilized and easy to fly while its integrated design makes assembly and configuration simple and fast. Retractable landing gear, vibration dampers, slightly angled arms and a minimized gimbal mount allow for a clear 360 degree view from the camera. A patented power distribution board, built-in high-speed ESCs and motors with high efficiency propellers ensure dynamic stability and maximized power efficiency. Used with a professional DJI multi-rotor autopilot system, the S1000+ can hover and fly reliably making it ideal for photography and cinematography.

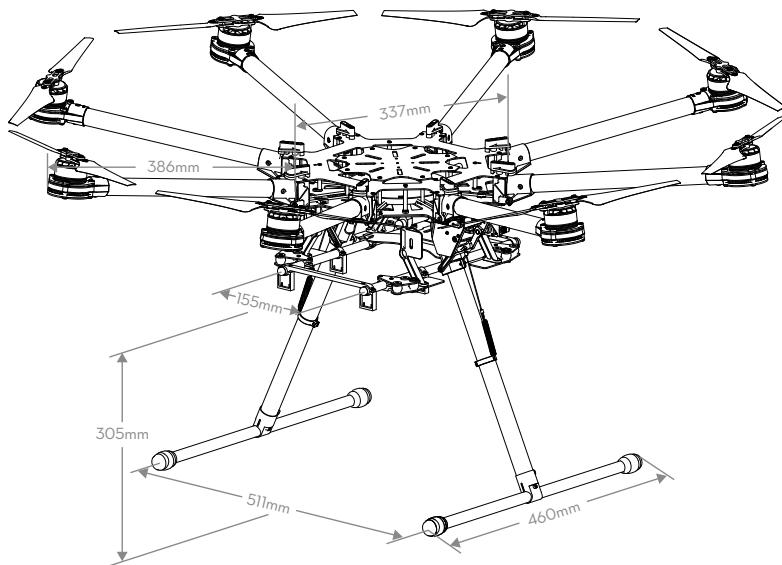

# Contents

Disclaimer	2
About	2
Cautions	4
Legend	4
In The Box	5
Mounting the Landing Gear	6
Mounting Frame Arms	7
Mounting Electronics and Wiring	11
Connecting XT60 Ports on the Center Frame	16
Installing Battery	16
Setting Up the Landing Gear	18
Mounting the Gimbal	20
Appendix	22
ESC Sound	22
ESC LED	22
Specifications	22
Gain Value Settings	23
FAQ	24
Soldering the ESC	24
Remounting the Propellers	24
Propeller Precautions	24
Using the Propeller Holder	25
Assembling Motor Vibration Absorbers	25
Remounting the Landing Gear Servo	26
Recalibrating Servo Travel	26
Part List	27
FCC Statements	31

# Cautions

When flying, the rotating propellers may cause serious damage and injury. Please fly safe at all times.

## Assembly Cautions

1. Use a bracket to mount the GPS module on the center frame to avoid interference with the power board.
2. Ensure the IMU is mounted with the arrow pointing toward the nose of the aircraft.
3. If using a receiver, attach it under the bottom board of the center frame with the end of the antenna facing downwards and away from obstructions to avoid signal loss.
4. Ensure frame arms are mounted correctly.
  - a) Motor mounts with CCW marks should be mounted to the center frame positions with the following marks: M1, M3, M5 and M7.
  - b) Motor mounts with CW marks should be mounted to the center frame positions with the following marks: M2, M4, M6 and M8.
5. Do not remove any glued-in screws.
6. Screws that already have blue glue can be used once without thread locker. On other occasions, apply appropriate thread locker first.
7. The S1000+ should be lifted off the ground when testing landing gear or recalibrating servo travel.

## Flight Cautions

1. ESCs are not water-proof, please do not fly in rain or snow.
2. **Ensure all soft dampers and vibration absorbers are in good condition before every flight. If not, replace immediately. Otherwise, the flight performance of your aircraft will be adversely affected.**
3. Ensure all parts are in good condition before each flight. Do not fly with worn or broken parts.
4. Ensure propellers and motors are installed correctly and propellers are unfolded before flying.
5. Ensure ESC signal connectors and power cable connectors are tight before every flight.
6. When flying, maintain a safe distance away from people, buildings, high-voltage lines, tall trees, water and other hazards.
7. Use only 6S LiPo batteries for the power supply.
8. Ensure all output signals from M1 to M8 are in proper working order when using the DJI A2 flight control system to avoid damage or injury.
9. Do not overload the system.
10. Do not get close to or touch motors or propellers when they are spinning as this can cause serious injury.
11. Disconnect the battery and remove the camera during transportation to avoid damage or injury.
12. We strongly recommend using as many DJI manufactured parts as possible.

## Others

If you have any problems you cannot resolve, contact your dealer or DJI customer service.

# Legend









Important

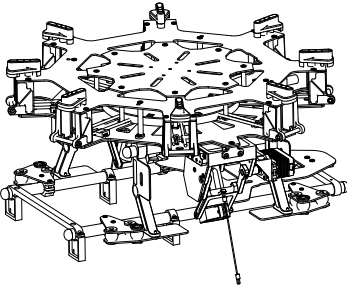
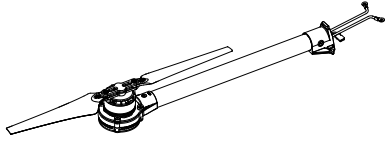
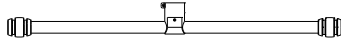

Hints and Tips



# In The Box

Center Frame x1	Frame Arms x8
	
Landing Skid Tubes x2 (with Silicone Rubber Dampers)	Landing Gear Legs x2
	
GPS Collapsible Mount x1	Springs x2
	
Connection Cable	Accessories Package x1
<p>Connector Set x1</p>  <p style="text-align: center;">or</p> <p>3-PIN Connection Cables x8</p> 	<p>CW propellers x2</p> <p>CCW propellers x2</p> <p>Magic tapes x4</p> <p>The red knobs x8</p> <p>Soft dampers x50</p>
Screw Package x1	
<p>For frame arms mount: M4x35</p> <p>For landing gear mount: M3x8, M2.5x8 (socket cap), M3x22 (socket cap)</p>	

## Tools Required

Tools	Usage
2.0mm Hex Wrench, 2.5mm Hex Wrench	Mounting screws.
Thread Locker	Fastening screws.
Nylon Cable Tie, Scissors, Cutting Pliers/Dykes	Binding devices and wires.
Foam Double Sided Adhesive Tape	Mounting receiver, controller and other modules.

# Mounting the Landing Gear

## Instructions

1. Insert one landing gear leg into each landing skid tube and secure it in place by tightening the M2.5x8 (socket cap) screw. Ensure silicone rubber dampers are attached to each end.
2. Insert the landing gear leg into connection point on the center frame. Affix in place with M3x8 screws.
3. Connect both springs on the legs to the center frame.

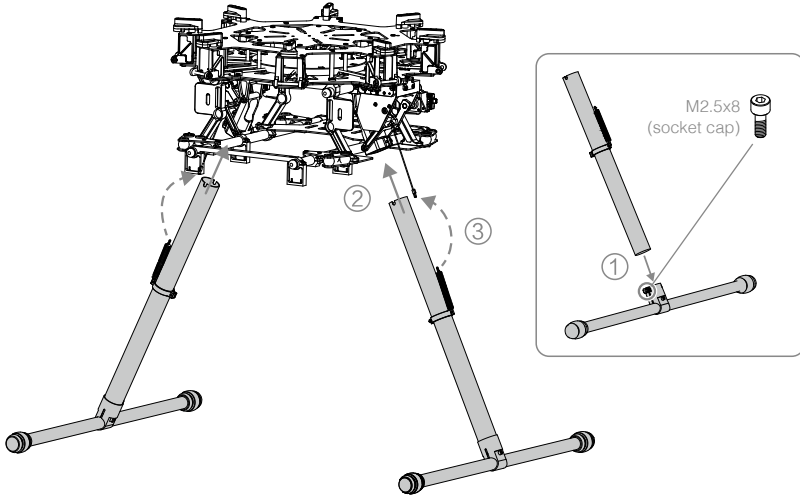

Note the springs are 58.5mm before connecting to the center frame, and are stretched to 70mm when mounting is completed.

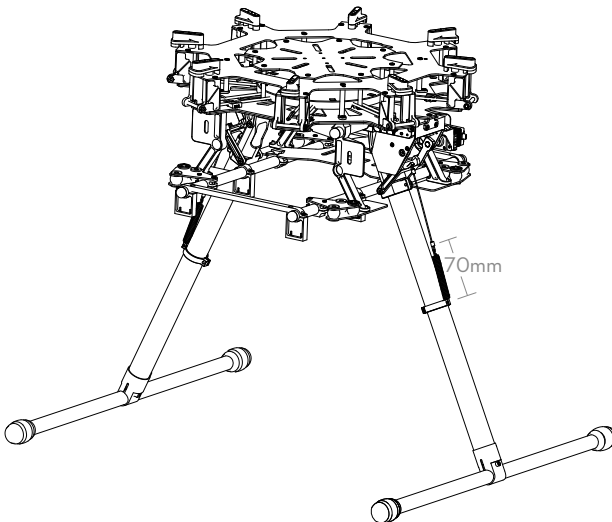

# Mounting Frame Arms

## Instructions

1. Prepare the arms.
  - (1) Check all propellers for cracks, then install and screw each propeller cover on tightly.
  - (2) Ensure all motors are mounted firmly and rotate freely.
  - (3) Mount all arms with red propeller covers to M1 and M2 to indicate the nose of the S1000+.
  - (4) Identify the CW and CCW marks on the arms. Mount the arms with the CCW mark to the M1, M3, M5 and M7 positions of the center frame. The arms with the CW mark should be mounted to the M2, M4, M6 and M8 positions of the center frame.

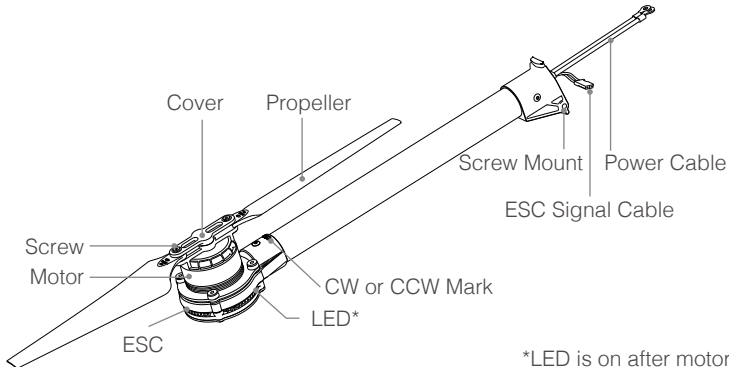

\*LED is on after motor started.

2. Insert each frame arm vertically into the mounting area on the center frame.
3. Line up the screw holes of the frame arm and center frame.
4. Insert the M4x35 screw from the right of the frame arm (the thread is located on the left of the screw mount). Tighten each screw correctly. Over tightening may lead to connector abrasion.

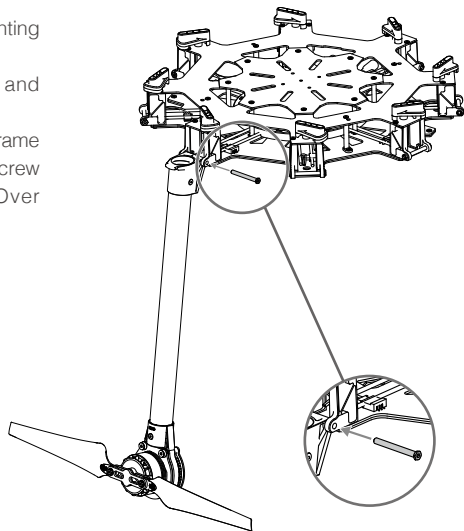

5. Gently lift the frame arm.
6. Twist the red knob to lock each arm in place. Be sure there is an audible click, which indicates a proper lock. Check the arm for movement. To store, untwist the knob and lower the frame arm.

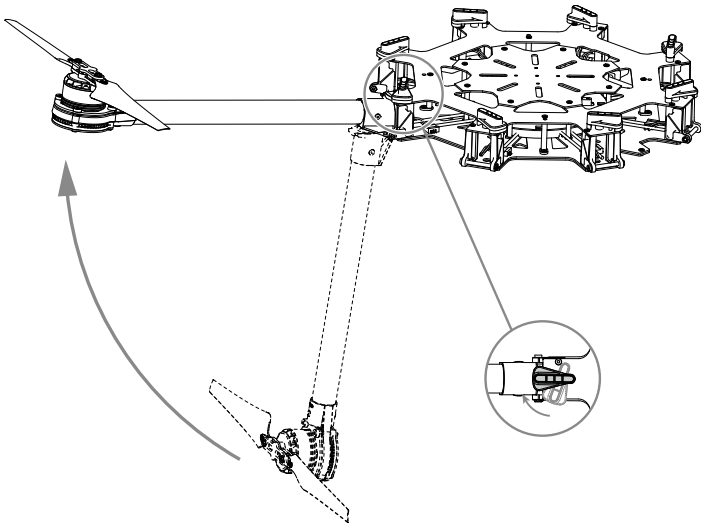

7. Now unscrew 8 screws (M2.5x8 cheese) on the upper plate of the center frame and remove the upper plate. Then unscrew the 4 screws (M3x8 self-tapping, found under the center frame) of the round cover and remove it to gain access to the ESC and power cable installation area.
8. Plug each ESC signal cable into the slot near each arm on the center frame.

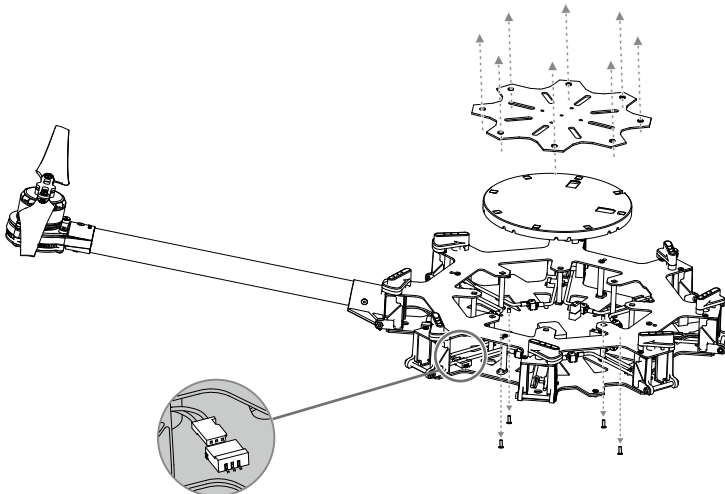

9. Connect the power cables to the center frame. Each cable must be screwed into a positive (+) or negative (-) gold bracket. Each bracket will have two cables of the same color screwed into it. Red cables are positive and black cables are negative.
10. To ensure a reliable connection, rotate the screw until it is both tight and parallel to the connecting bracket.

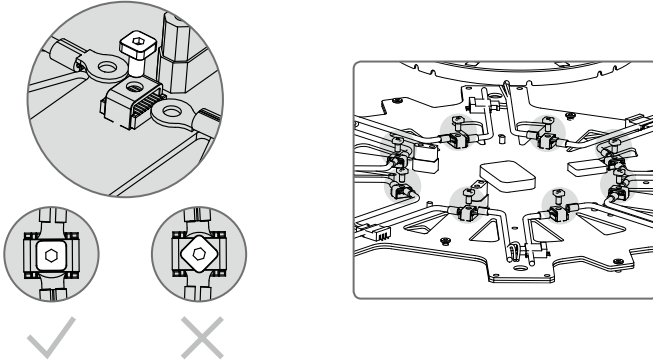

11. Ensure all ESC cables, and power cables are correctly installed onto the center frame.

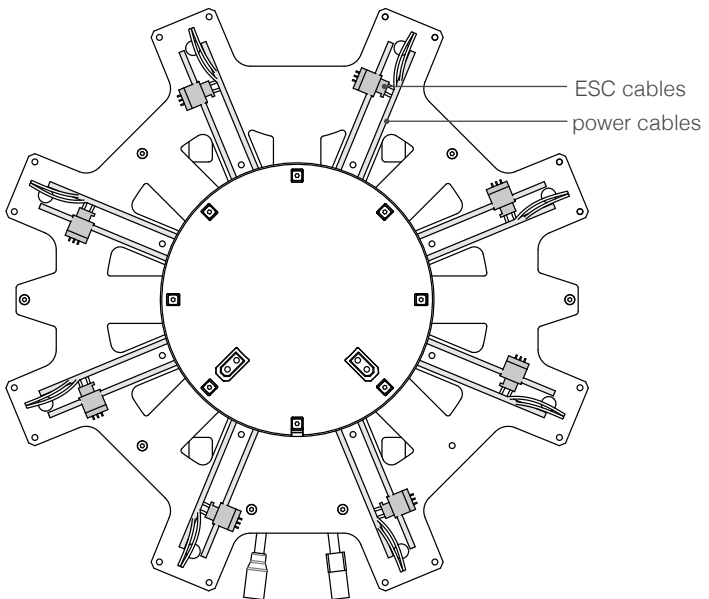

12. Replace the round cover of the center plate, and re-tighten the 4 screws (M3x8 self-tapping). Then replace the upper plate of the center frame, and re-tighten the 8 screws (M2.5x8 cheese).

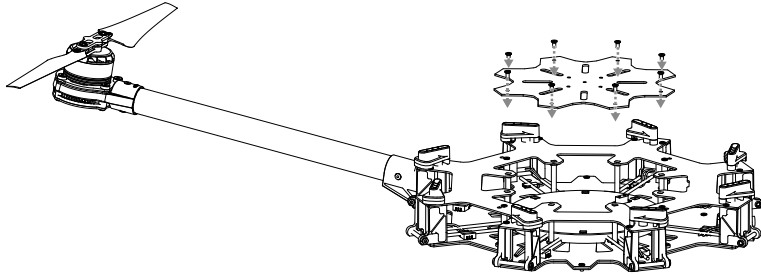

13. Double check all frame arms. Arms M1 and M2 are the forward facing (nose), arms M5 and M6 are the tail. Seen from the top, motors on arms M1, M3, M5 and M7 rotate counter clockwise while those on arms M2, M4, M6 and M8 rotate clockwise.

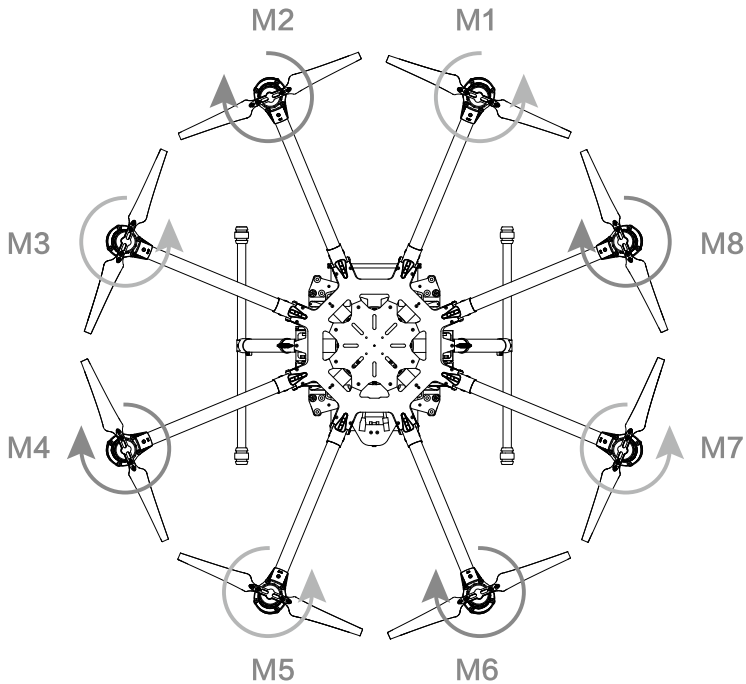

# Mounting Electronics and Wiring

Eight positions are reserved for mounting a flight control system, wireless video transmission module, receiver, and other accessories. The DJI A2 flight control system has been used here as an example. If using an A2, follow mounting and wiring instructions found in the A2 flight control system user manual. If using the DJI WK-M flight control system, please refer to the WK-M user manual for connections. Also be sure the firmware on your DJI flight controller has been updated to the latest version.

## Instructions

1. Attach IMU module to the IMU area of the center frame. Ensure that it points toward the nose.
2. Attach the PMU module to the center frame.

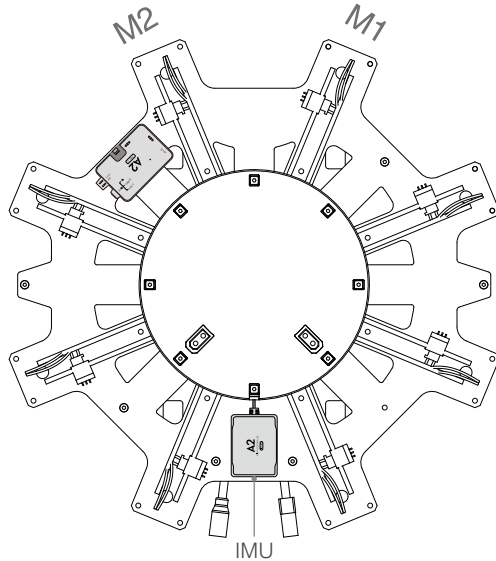

 Only mount the IMU in the IMU position of the center frame.

3. Mount the flight controller in the reserved position near the PMU module.

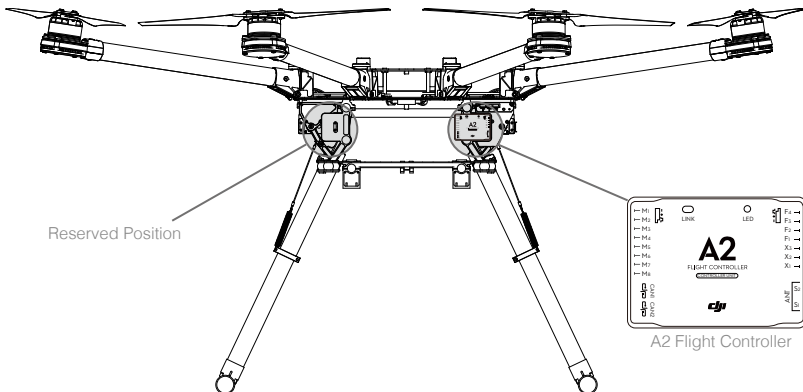

4. Attach the GPS collapsible mount to the center frame using M2.5x8 screws.
5. Mount a GPS module to the GPS mount with a bracket. Ensure the arrow points toward the nose and avoid catching your fingers in the bracket when folding for transportation.

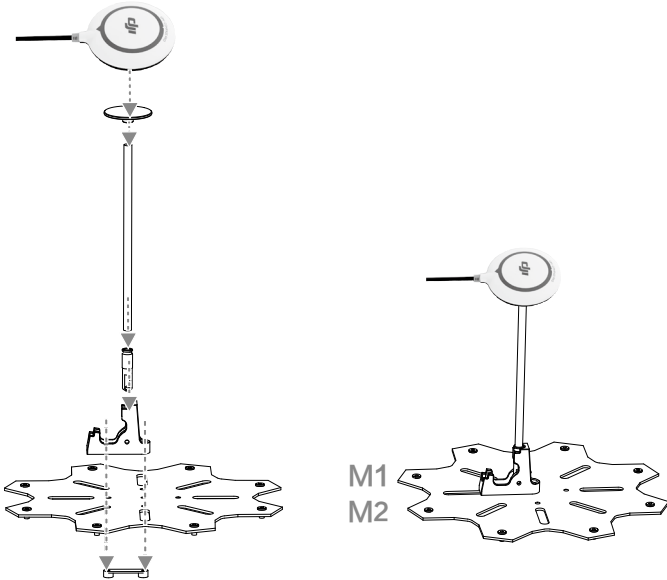

6. The other reserved positions are indicated in the diagram below and can be used for mounting a receiver, LED flight indicator, iOSD module and wireless video transmission module.

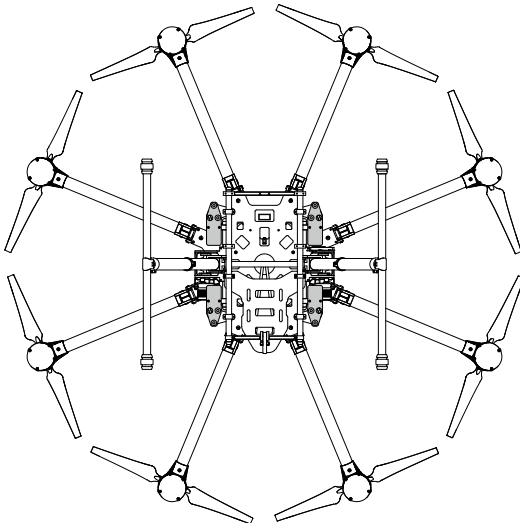



7. Check that each Anti-drop Kit has been firmly installed in the reserved positions.
8. Note that the dampers are 45° silicon rubber. If you use other dampers or vibration absorbing balls, the quality of your aerial photography may be affected.

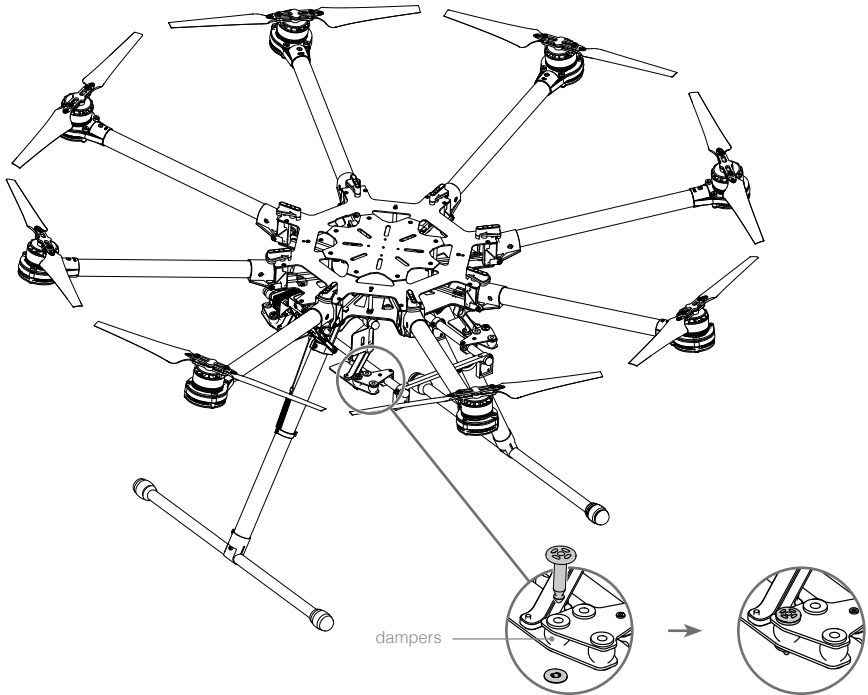

- Mount the GPS with a bracket to avoid interference from the center frame power board.
- Use glue to install the GPS bracket. Ensure it is firm and stable before every flight.
- Once the Anti-drop Kit is installed and the pin is inserted into the washer, the Anti-drop Kit cannot be disconnected and reused.
- Always test motors using the Assistant after installation. Refer to your flight control system user manual for details.

## Connecting the flight controller to the center frame

1. Connect the flight control system according to your flight control system user manual.
2. Connect the flight controller to the center frame with the connection cables.

There are two kinds of connection cables. Choose the corresponding connection mode according to the connection cable in the box.

### Using the connector set:

Plug in the connector set to the ESC signal outlet on the center frame. Then plug in the connector set to flight controller as shown below.

- (1) Yellow 4-pin cables are for M1~ M4 connections. The yellow cable should be connected to M1.
- (2) Brown 4-pin cables are for M5~ M8 connections. The brown cable should be connected to M5.
- (3) Black 4-pin cables are for four continuous ground pins connections. M1~M4 are connected as the following diagram shows.

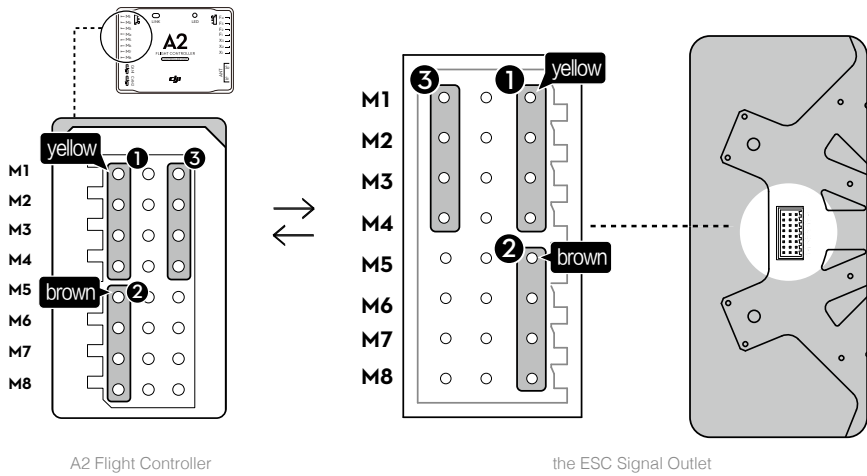

### Using the 3-pin connection cable:

M1 through M8 correspond to each motor number.

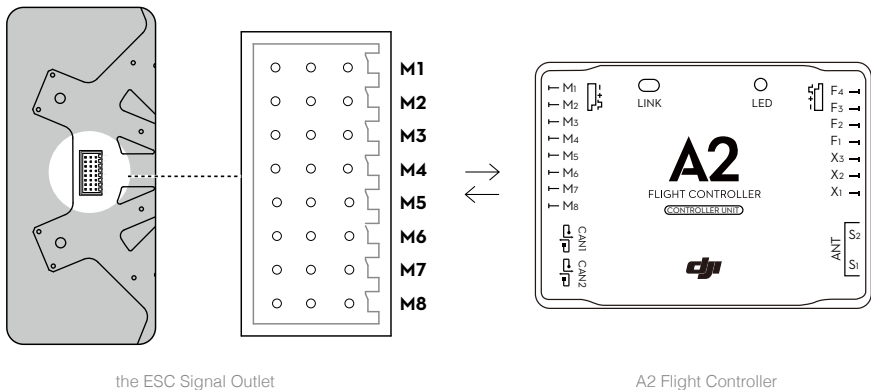

**!** If using a DJI WK-M flight control system, you must use the wires that came with the WK-M. M1 through M6 correspond to each motor number. M7 corresponds to F1 and M8 corresponds to F2 on the WK-M.

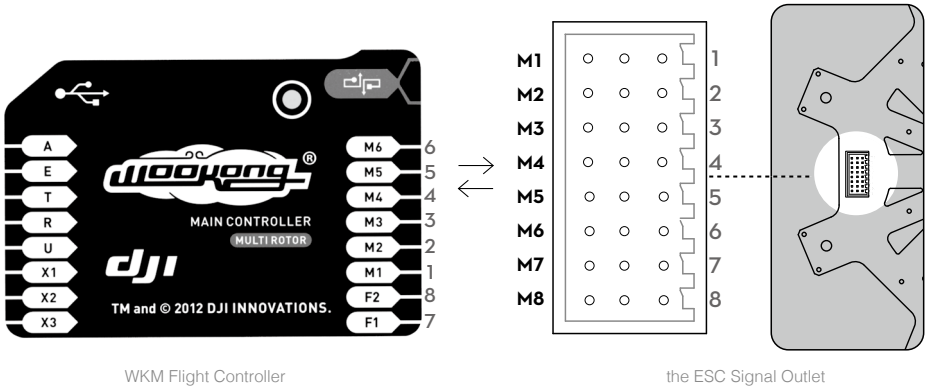

### Connecting the flight controller and landing gear

1. Connect the left servo (between M3 and M4) cable to the "L" port of the landing gear control board.
2. Connect the right servo (between M7 and M8) cable to the "R" port of the landing gear control board.
3. For the A2 flight control system, connect the F1 port of the flight controller to the "IN" port of the landing gear control board. Other flight control systems connect a 2-position channel receiver to the "IN" port.

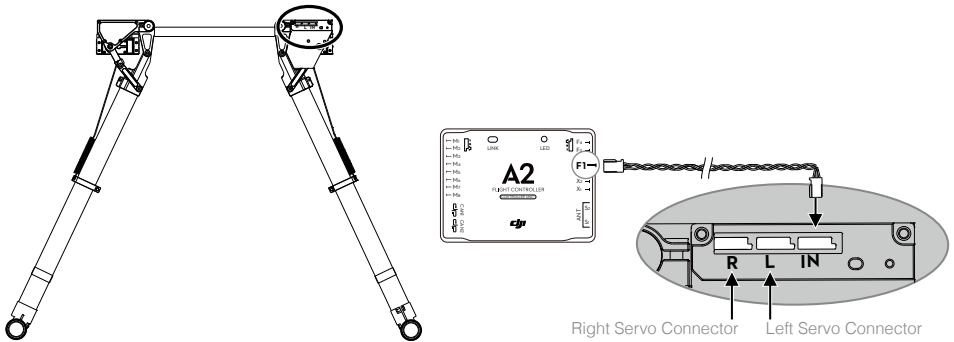

- !**
- If right and left servo cables are reversed, the landing gear will not function properly.
  - Connect all wires carefully and neatly to avoid cable damage caused by frame edges.

# Connecting XT60 Ports on the Center Frame

The bottom board is a power distribution board with three XT60 connectors for battery power.

## Instructions

1. Connect the PMU power cable to the XT60 connector on top of the bottom board.
2. Connect the landing gear control board cable to the XT60 connector on the bottom of the bottom board.
3. Other connectors can supply power for other DJI devices, as required.

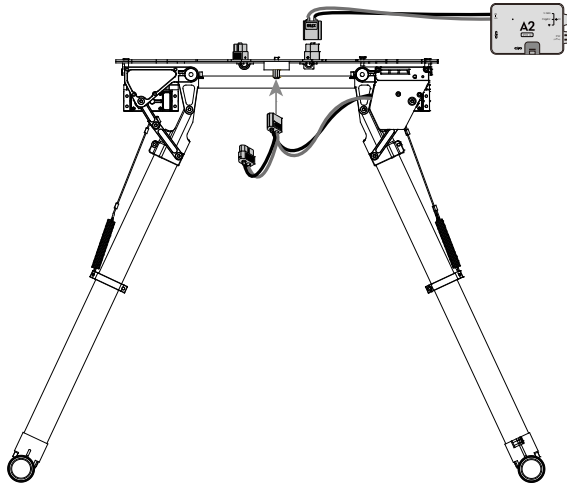

## Installing Battery

### Soldering battery connectors

AS150 spark-proof connectors are used. They must be soldered to your battery power cables.

1. Remove the original battery connectors. Avoid cutting the power and ground cables at the same time, as this can cause a short circuit. We recommend wrapping unsoldered cables with insulating tape to prevent accidental connections.
2. Pass the black ground wire through the black housing. After passing the wire through, solder the female bullet connector to the ground wire. Wait for the soldered connection to cool, then pull the housing back over the bullet connector.
3. Screw and pass the red power wire through the red housing. After passing the wire through, solder the male bullet connector to the power wire. Wait for the soldered connection to cool, and then screw and pull the housing back over the bullet connector.

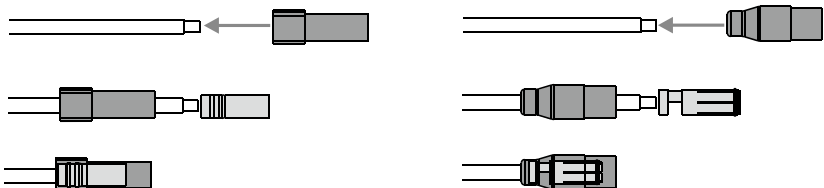

Connectors soldering diagram

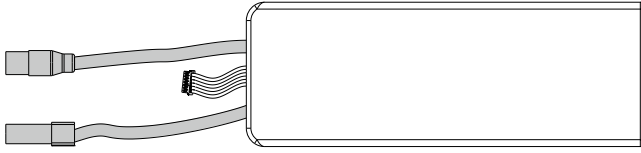

Connectors are soldered

### Installing and connecting battery

1. Attach battery to battery tray. Do not use an oversized battery. Maximum installation dimension is 80mm×120mm×200mm.
2. Connect the black connector and then the red connector to power on. Disconnect the red connector then black connector to power off.

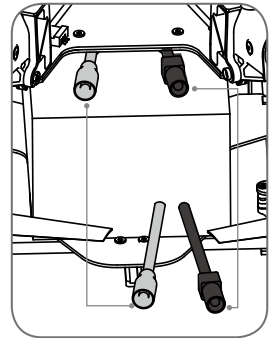
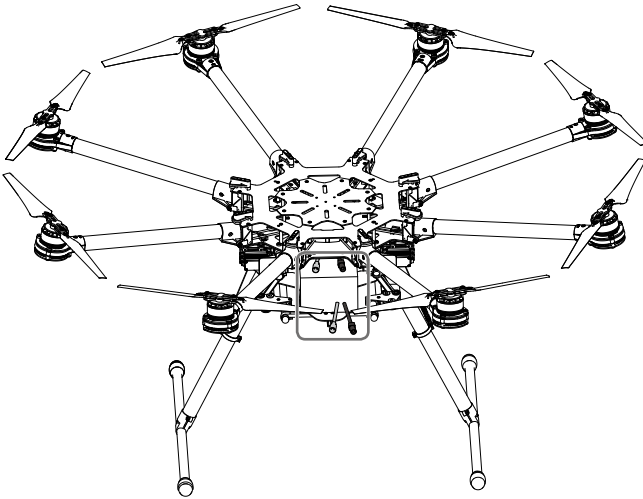

Inspect the surface of the battery connectors regularly. Replace connectors with signs of blackening due to oxidation. Failure to do so may lead to serious flight accidents.

# Setting Up the Landing Gear

Using a 2-position RC transmitter switch, landing gear retraction can be carried out remotely.

## Setting up the transmitter

Select a 2-position switch (default setting is OK) as the control input for the landing gear. Ensure the corresponding receiver port is connected to the "IN" port on control board. For the A2 flight control system, connect the flight controller's F1 port to "IN" port on control board.

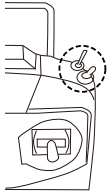

Upper: Toggle the switch to this position to raise the landing gear.



Lower: Toggle the switch to this position to lower the landing gear.

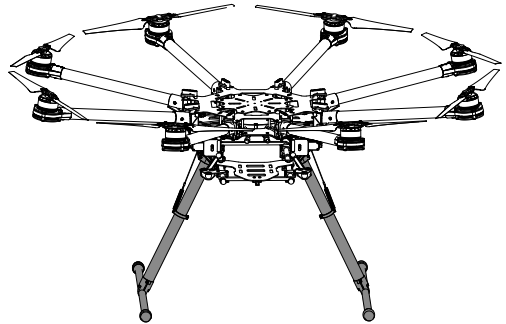
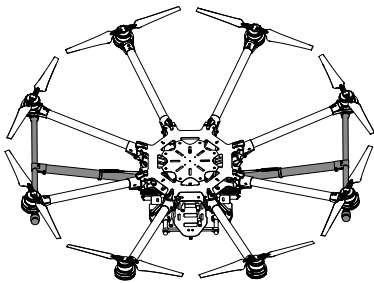

- If the transmitter switch has a FailSafe function, set the FailSafe value to the [Lower] position. This ensures that the landing gear will lower automatically when the receiver enters FailSafe mode.
- To avoid accidental switch triggering, slide levers or other controls can be used for landing gear control.

## Usage procedures

1. Ensure transmitter and receiver batteries are fully charged.
2. Toggle the switch to the [Lower] position, and then turn on the transmitter.
3. Ensure the "R", "L" and "IN" connections are correct.
4. Ensure the landing gear is in the [Lower] position, then power on the system. If a solid green LED on the landing gear control board lights up, everything is normal. If it flashes green slowly, re-calibrate the system according to instructions in "Recalibrating Servo Travel".
5. Toggle the switch to the [Upper] position ONLY AFTER takeoff.
6. Toggle the switch to the [Lower] position for landing.



- Servo power will shut off 3 seconds after the landing gear has reached its target position.
- When powering on the system, if the transmitter switch is in the [Upper] position, the LED will flash red quickly as a warning. Toggle the switch to the [Lower] position to continue.
- If there is an abnormal signal or no signal input into the "IN" port, the LED will slowly flash red. Check receiver and connections for problems.
- If servo power consumption is too high, the LED will light up red. If this lasts more than 4 seconds, the landing gear will lower and the LED will flash green slowly. Re-calibration is needed before flying.
- A2 flight control system users can use the A2 Assistant to set intelligent gear on the "Advanced" page. Refer to the "A2 user manual" for details.

### LED Control Board Indicator

System normal	— Solid green.
Calibration required	..... Blinks rapid green.
Recalibration required	..... Blinks slow green.
Calibration failed	— Solid yellow.
Enter calibration mode	..... Blinks rapid yellow.
System calibrating	..... Blinks slow yellow.
Motor stalled	— Solid red.
Unsafe startup alert	..... Blinks rapid red.
Input signal abnormal	..... Blinks slow green.

### Landing Gear Specifications

Parameter	Range	Parameter	Range
Working Voltage	3S~6S (LiPo)	Input Signal	PWM (High-Pulse Width 800us~2200us)
Working Current	Max 1A@6S	Output Signal	PWM (Mid Position is 1520us) in 90Hz
Working Temperature	-20~70° C	Output Voltage	6V
Total Weight	875g	Servo Travel	150° (Minimum 120° )

# Mounting the Gimbal

Before assembling the gimbal, install the GCU as shown below. Be sure to install on the side as shown below. A DJI Z15-5D MARK III (HD) gimbal has been used as an example in the following diagrams.

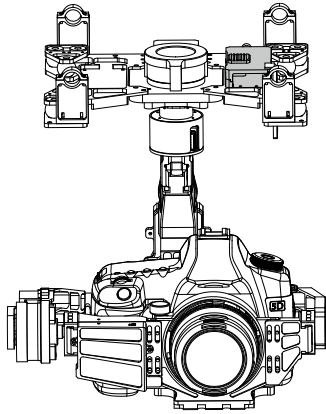

The connectors on gimbal should be removed for better performance, then the gimbal can be mounted to the lower connection points.

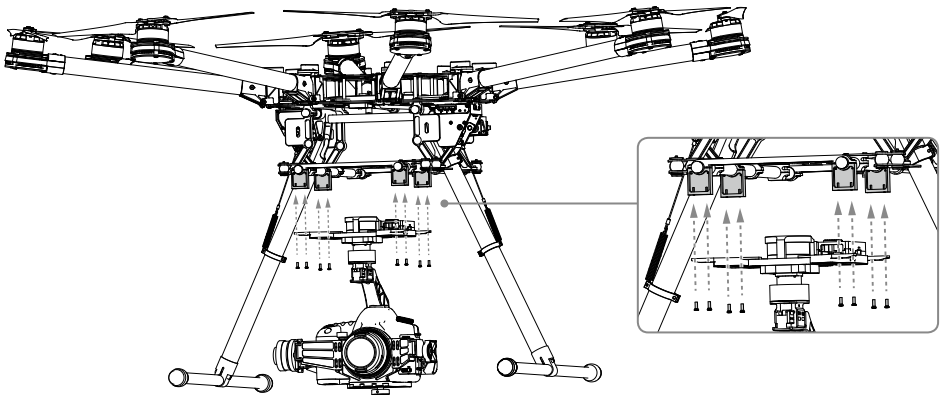



Check that the system's center of gravity is on the line as shown in the diagram below.

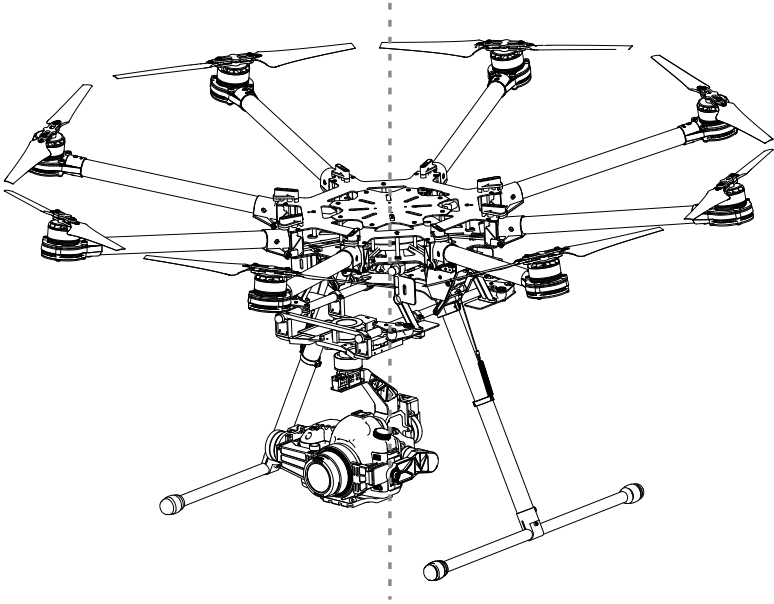

# Appendix

## ESC Sound

ESC State	Sound
Ready	♪1234567--B--B
Throttle stick is not at bottom	BBBBBB...
Input signal abnormal	B-.....B-.....B...
Input voltage abnormal	BB...BB...BB...BB...

## ESC LED

ESC State	LED
Standby	Off
Motor rotating	Solid Red or Green On
Motor rotating at full throttle position	Solid Yellow On



DJI ESCs are specifically designed for multi-rotors. When used with DJI autopilot systems parameters and travel ranges do not have to be calibrated.

## Specifications

### Frame

Diagonal Wheelbase	1045mm
Frame Arm Length	386mm
Frame Arm Weight (with Motor, ESC, Propeller )	325g
Center Frame Diameter	337mm
Center Frame Weight (with Landing Gear Mounting Base, Servos)	1520g
Landing Gear Size	460mm(Length)×511mm(Width)×305mm(Height)

### Motor

Stator Size	41×14mm
KV	400rpm/V
Max Power	500W

Weight (with Cooling Fan)	158g
---------------------------	------

## ESC

Working Current	40A
Working Voltage	6S LiPo
Signal Frequency	30Hz ~ 450Hz
Drive PWM Frequency	8KHz
Weight (with Radiators)	35g

## Foldable Propeller (1552/1552R)

Material	High strength performance engineered plastics
Size	15×5.2 inch
Weight	13g

## Flight Parameters

Takeoff Weight	6.0Kg ~ 11.0Kg
Total Weight	4.4Kg
Power Battery	LiPo (6S, 10000mAh~20000mAh, 15C(Min))
Max Power Consumption	4000W
Hovering Power Consumption	1500W (@9.5Kg Takeoff Weight)
Hovering Time	15min (@15000mAh & 9.5Kg Takeoff Weight)
Working Environment Temperature	-10° C ~ 40° C

## Gain Value Settings

Flight Control	Basic			Attitude		
	Pitch	Roll	Yaw	Pitch	Roll	Vertical
A2	120%	120%	120%	170%	170%	120%
WooKong-M	130%	130%	100%	180%	180%	100%

# FAQ

## Soldering the ESC

Be sure to solder the thick wires and fine wires correctly when soldering an ESC to the frame arm. Clockwise (CW) and counter clockwise (CCW) motors have a different arrangement of the colored wires.

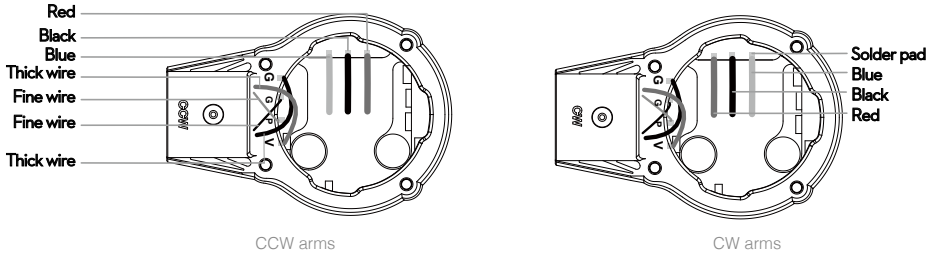

## Remounting the Propellers

### Instructions

1. Use two M3x12.3 screws and four washers to remount propellers.
2. Apply thread locker to the thread of the propellers mount first.
3. Affix screws with 3Kg · cm (0.3N · m) torque.

 Refer to original screw tensions if you are unfamiliar with torque measurements. Applying thread locker to the propeller mount first avoids getting thread locker into the holes of the plastic propeller.

 Loose screws cannot be securely locked with thread locker.

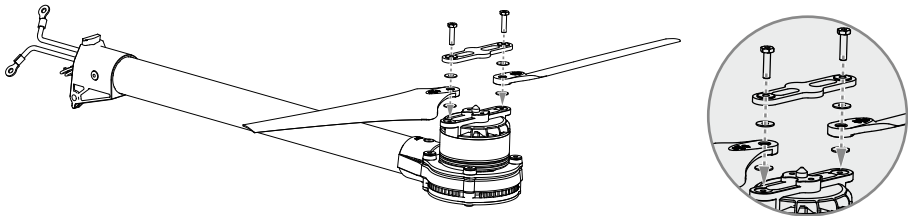

## Propeller Precautions

Torque markers on the screws and propeller covers will give you a visual cue to check whether the propellers are loose. Check the torque markers before every flight.

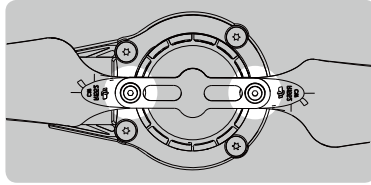

## Using the Propeller Holder

### Instructions

1. Insert the propeller blades into the propeller holder.
2. Attach the propeller holder to the frame arm.

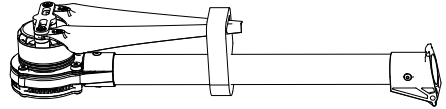
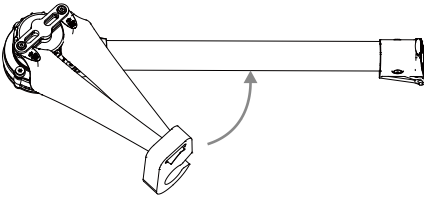

## Assembling Motor Vibration Absorbers

A soft damper is part of the vibration absorber. Assemble soft dampers as shown below. Assembly is the same for CCW and CW propellers.

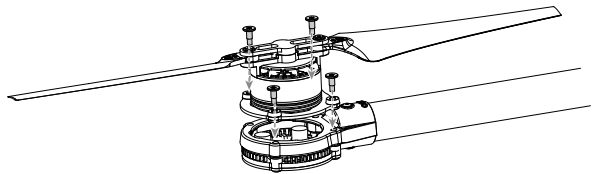
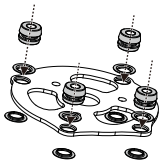

- Ensure all soft dampers and vibration absorbers are in good condition before every flight. If not, replace immediately. Otherwise, the flight performance of your aircraft will be adversely affected.
- Before installing the soft dampers, put the copper gaskets onto the four mounting holes on the carbon plate. Then put the soft dampers into the mounting holes.
- After tightening the screws, the vibration absorbers may be twisted. If this is the case, hold the motor with your thumbs under the base plate and fingers on the top carbon plate, and squeeze the plates together to make the vibration absorbers flat and parallel with the plates.

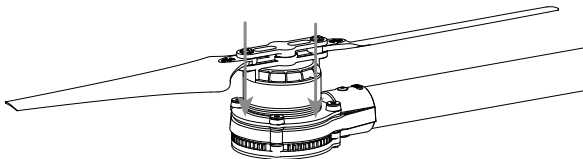

## Remounting the Landing Gear Servo

Remounting servos is not recommended as they are pre-installed.

### Instructions

1. Connect the left servo cable to the "L" port of the landing gear control board.
2. Connect the right servo cable to the "R" port of the landing gear control board.
3. Press and hold the SET button using a pin then power on. You will see a yellow LED beside the SET button flashing quickly. Wait as servos complete position initialization.
4. Make sure the arm connecting to the servo is parallel to the link as shown in the following diagram.
5. Assemble the left and right servos to the left (between M3, M4) and the right (between M7, M8) parts of the landing gear. Power off.

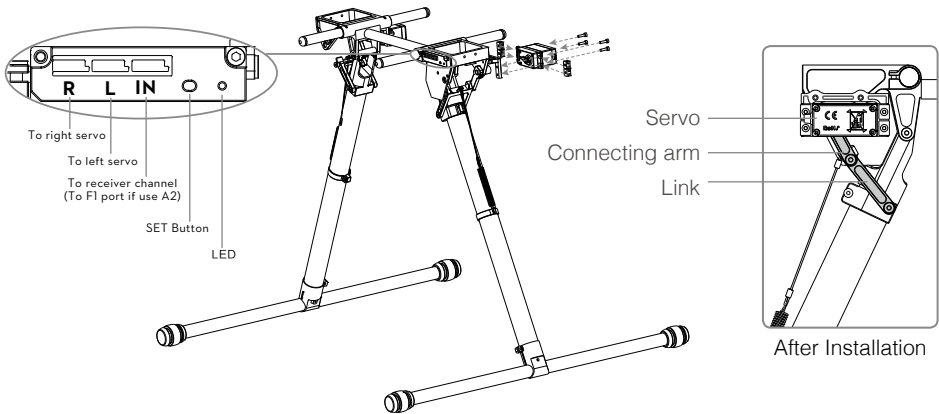

## Recalibrating Servo Travel

### Instructions

1. Keep your hands away from all moving parts.
2. Ensure the "R", "L" and "IN" connections are correct.
3. Keep the whole aircraft off of the ground during calibration, as landing gear will move.
4. Press and hold the SET button using a pin while powering on, then release. An LED will flash yellow quickly. Press the SET button again. Auto calibration will begin and the LED will flash yellow slowly. DO NOT obstruct any moving parts during auto calibration.
5. During calibration, the left landing gear will raise and lower, followed by the right landing gear.
6. After calibration, both the left and right landing gears will be lowered and the LED will display a solid green light. This indicates that the landing gear is working properly.



- If the LED is solid yellow after calibration, a problem has occurred. Carry out the instructions in "Remounting the Landing Gear Servo" then try again.
- Avoid obstructions during calibration. If the landing gear was obstructed, recalibration will be required, per the above steps.
- If the "R" and "L" servo cables are reversed, travel will not be measured correctly. Fix the connections and recalibrate the landing gear using the above steps.
- Landing gear travel has been pre-calibrated. Mechanical adjustment of the gear travel is not recommended.



21	S1000+ 4114 Motor with black Prop cover	S1P012101B, S1P012102B, M3x4.5
22	S1000+ 4114 Motor with red Prop cover	S1P012201R, S1P012202R, M3x4.5
23	S1000+ ESC with Red LED	S1P012301R, S1P012302, M3x12.3 (cheese)
24	S1000+ ESC with Green LED	S1P012401G, S1P012402, M3x12.3 (cheese)
25	S1000+ Propeller Pack	S1P012501CCW, S1P012502CW, S1P012503, M3x12.3 (hexagan)

### Center Frame

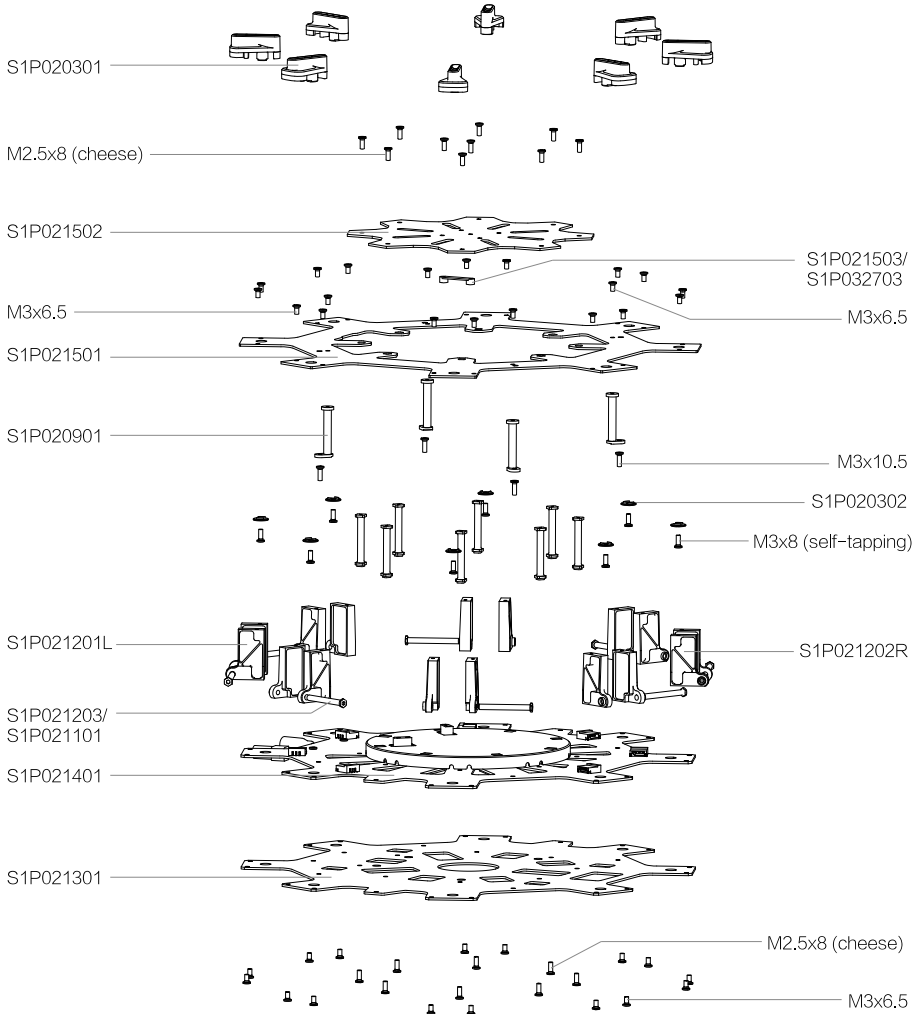



Package No.	Name	Part No.
3	S1000+ Lock Knob	S1P020301, S1P020302, M3x8 (self-tapping)
9	S1000+ Center Frame Support Pillar	S1P020901, M2.5x8 (cheese)
12	S1000+ Arm Mounting Bracket	S1P021201L, S1P021202R, S1P021203, M3x6.5
14	S1000+ Center Frame Bottom Board	S1P021401, M3x4.5 (cheese), M3x8 (self-tapping), M3x6.5, M3x5.5
15	S1000+ Center Frame Top Board	S1P021501, S1P021502, S1P021503, M3x6.5, M2.5x8 (cheese)
11	S1000+ Frame Arm Mounting Steel Shaft	S1P021101

### Landing Gear

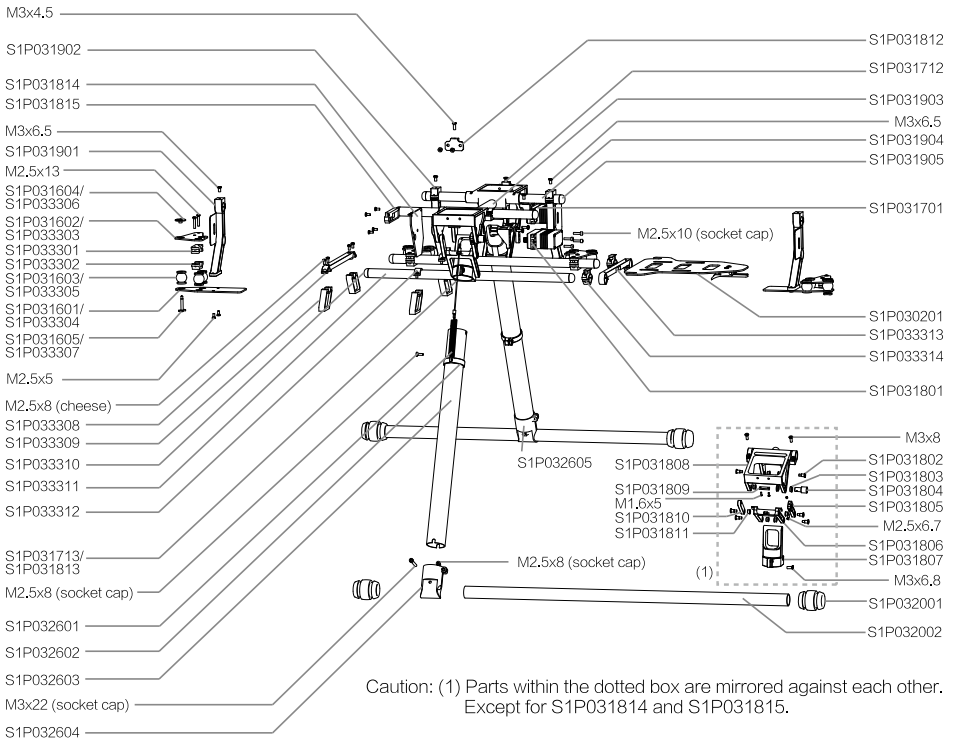

Caution: (1) Parts within the dotted box are mirrored against each other. Except for S1P031814 and S1P031815.

Package No.	Name	Part No.
16	S1000+ Gimbal Damping Bracket	S1P031601, S1P031602, S1P031603, S1P031604, S1P031605, M2.5x5, M2.5x13
17	S1000+ Retractable Module (Right)	S1P031701, S1P031702, S1P031703, S1P031704, S1P031705, S1P031706, S1P031707, S1P031708, S1P031709, S1P031710, S1P031711, S1P031712, S0031713, M1.6x5, M2.5x10 (socket cap), M2.5x8 (cheese), M2.5x5, M3x8, M3x4.5, M3x6.8
18	S1000+ Retractable Module (Left)	S1P031801, S1P031802, S1P031803, S1P031804, S1P031805, S1P031806, S1P031807, S1P031808, S1P031809, S1P031810, S1P031811, S1P031812, S1P031813, S1P031814, S1P031815, M1.6x5, M2.5x10 (socket cap), M2.5x8 (cheese), M2.5x5, M3x8, M3x4.5, M3x6.8
19	S1000+ Gimbal Damping Connecting Brackets	S1P031901, S1P031902, S1P031903, S1P031904, S1P031905, M2.5x5, M3x6.5
20	S1000+ Landing Skid	S1P032001, S1P032002
26	S1000+ Landing Gear Leg	S1P032601, S1P032602, S1P032603, S1P032604, S1P032605, M2.5x8 (socket cap), M3x22 (socket cap)
2	S1000+ Battery Tray	S1P030201
33	S1000+ Gimbal Mounting Accessories	S1P033301, S1P033302, S1P033303, S1P033304, S1P033305, S1P033306, S1P033307, S1P033308, S1P033309, S1P033310, S1P033311, S1P033312, S1P033313, S1P033314, M2.5x5, M2.5x13, M2.5x8 (cheese)

Part List

Miscellaneous

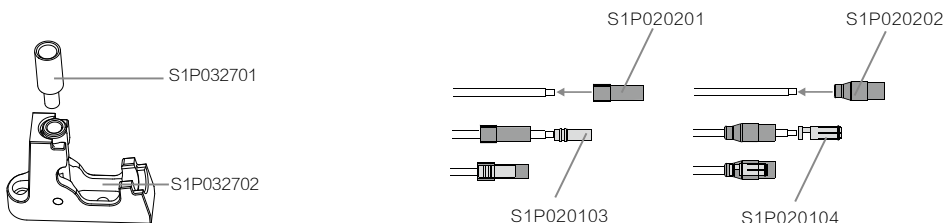

Package No.	Name	Part No.
13	S1000+ Center Frame	Package 3, 9, 12, 14, 15, S1P021301
29	S1000+ Complete Arm [CW-RED]	Package 7, 8, 10, 11, 22, 23, 25, S1P012901, S1P012902, S1P012903
30	S1000+ Complete Arm [CW-Green]	Package 6, 8, 10, 11, 21, 24, 25, S1P013001, S1P013002, S1P013003
31	S1000+ Complete Arm [CCW-RED]	Package 5, 8, 10, 11, 22, 23, 25, S1P013101, S1P013102, S1P013103
32	S1000+ Complete Arm [CCW-Green]	Package 4, 8, 10, 11, 21, 24, 25, S1P013201, S1P013202, S1P013203
27	S1000+ GPS Holder	S1P032701, S1P032702, S1P032703, M2.5x8 (cheese)
28	S1000+ Screw Pack	Assorted screws
1	S1000+ Power Cord Plug	S1P020101, S1P020102, S1P020103, S1P020104

## FCC Statements

This equipment has been tested and found to comply with the limits for a Class A digital device, pursuant to part 15 of the FCC Rules. These limits are designed to provide reasonable protection against harmful interference when the equipment is operated in a commercial environment. This equipment generates, uses, and can radiate radio frequency energy and, if not installed and used in accordance with the instruction manual, may cause harmful interference to radio communications. Operation of this equipment in a residential area is likely to cause harmful interference in which case the user will be required to correct the interference at his own expense.

The content is subject to change.

**Download the latest version from**  
**<http://www.dji.com/product/spreading-wings-s1000-plus>**



If you have any questions about this document, please contact DJI by sending a message to [DocSupport@dji.com](mailto:DocSupport@dji.com).